

红宝石球测针 (不锈钢测杆)

订货号	A-5003-3550	A-5000-7545	A-5000-7547	A-5000-7549	A-5000-7551
A 测球直径 mm (in.)	5.0 (0.20)	1.0 (0.04)	2.0 (0.08)	3.0 (0.12)	4.0 (0.16)
B 长度 mm (in.)	10.5 (0.42)	19.5 (0.77)	19.0 (0.75)	18.5 (0.73)	18.0 (0.71)
C 测杆直径 mm (in.)	3.5 (0.14)	0.7 (0.03)	1.4 (0.05)	2.0 (0.08)	3.0 (0.12)
D EWL* mm (in.)	5.5 (0.22)	4.0 (0.16)	8.0 (0.32)	13.0 (0.52)	13.0 (0.52)
质量 (克)	2.0	2.5	2.3	2.0	2.1



订货号	A-5000-7553	A-5000-6731	A-5000-6352	A-5000-7555	A-5000-7557
A 测球直径 mm (in.)	5.0 (0.20)	5.0 (0.20)	5.0 (0.20)	6.0 (0.24)	8.0 (0.32)
B 长度 mm (in.)	18.0 (0.71)	20.0 (0.79)	30.0 (1.19)	17.5 (0.69)	16.0 (0.63)
C 测杆直径 mm (in.)	3.5 (0.14)	3.0 (0.12)	3.0 (0.12)	4.5 (0.18)	6.0 (0.24)
D EWL* mm (in.)	13.5 (0.54)	16.0 (0.63)	26.0 (1.03)	13.5 (0.54)	16.0 (0.63)
质量 (克)	2.3	2.4	3.0	3.0	3.9



10 mm –
30 mm系列

(碳化钨测杆)

订货号	A-5003-4792	A-5003-2932	A-5003-4793	A-5003-4794	A-5003-4795	A-5003-4796
A 测球直径 mm (in.)	1.0 (0.04)	2.0 (0.08)	3.0 (0.12)	4.0 (0.16)	5.0 (0.20)	6.0 (0.24)
B 长度 mm (in.)	20.0 (0.79)	20.0 (0.79)	20.0 (0.79)	20.0 (0.79)	20.0 (0.79)	20.0 (0.79)
C 测杆直径 mm (in.)	0.7 (0.03)	1.5 (0.06)	1.5 (0.06)	1.5 (0.06)	2.5 (0.10)	2.5 (0.10)
D EWL* mm (in.)	10.0 (0.40)	10.0 (0.40)	10.0 (0.40)	10.0 (0.40)	6.0 (0.24)	6.0 (0.24)
质量 (克)	2.39	3.01	3.53	3.53	4.52	4.66



20 mm系列

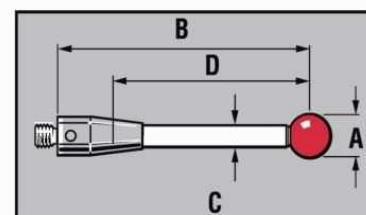

红宝石球测针

订货号	A-5000-7521 不锈钢	A-5003-0235 陶瓷	*A-5003-1436 碳纤维	A-5000-3709 陶瓷	A-5000-7795 陶瓷
A 测球直径 mm (in.)	5.0 (0.20)	5.0 (0.20)	6.0 (0.24)	6.0 (0.24)	8.0 (0.32)
B 长度 mm (in.)	50.0 (1.97)	50.0 (1.97)	50.0 (1.97)	50.0 (1.97)	50.0 (1.97)
C 测杆直径 mm (in.)	4.5 (0.18)	3.8 (0.15)	4.5 (0.18)	4.5 (0.18)	4.5 (0.18)
D EWL* mm (in.)	35.0 (1.38)	34.0 (1.34)	36.0 (1.42)	36.0 (1.42)	50.0 (1.97)
质量 (克)	5.8	5.0	4.1	4.8	5.4



50 mm系列

(碳化钨测杆)

订货号	A-5003-4797	A-5003-3680	A-5003-4799	A-5003-4800	A-5003-4801
A 测球直径 mm (in.)	2.0 (0.08)	3.0 (0.12)	4.0 (0.16)	5.0 (0.20)	6.0 (0.24)
B 长度 mm (in.)	50.0 (1.97)	50.0 (1.97)	50.0 (1.97)	50.0 (1.97)	50.0 (1.97)
C 测杆直径 mm (in.)	1.5 (0.06)	2.0 (0.08)	2 (0.08)	2.5 (0.10)	2.5 (0.10)
D EWL* mm (in.)	40.0 (1.58)	38.0 (1.50)	38.0 (1.50)	36.0 (1.42)	36.0 (1.42)
质量 (克)	3.80	4.94	4.99	6.72	6.86

50 mm系列

(陶瓷测杆)

A-5003-0236	A-5003-2764	A-5003-4802
5.0 (0.20)	6.0 (0.24)	8.0 (0.32)
75.0 (2.96)	75.0 (2.96)	75.0 (2.96)
3.8 (0.15)	4.5 (0.18)	4.5 (0.18)
59.0 (2.33)	63.5 (2.51)	75.0 (2.96)
5.63	5.64	6.20

75 mm 系列



订货号	A-5000-7522 不锈钢	A-5000-7523 不锈钢	A-5000-9761 陶瓷	A-5000-3712 陶瓷	A-5000-8156 陶瓷	*A-5003-1358 碳纤维	A-5000-7796 陶瓷	*A-5003-1255 碳纤维
A 测球直径 mm (in.)	5.0 (0.20)	5.0 (0.20)	5.0 (0.20)	6.0 (0.24)	6.0 (0.24)	6.0 (0.24)	8.0 (0.32)	6.0 (0.24)
B 长度 mm (in.)	100.0 (3.94)	150.0 (6.00)	100.0 (3.94)	100.0 (3.94)	150.0 (6.00)	100.0 (3.94)	100.0 (3.94)	150.0 (5.91)
C 测杆直径 mm (in.)	4.5 (0.18)	4.4 (0.17)	3.8 (0.15)	4.5 (0.18)	4.5 (0.17)	4.5 (0.18)	4.5 (0.18)	4.5 (0.18)
D EWL* mm (in.)	85.0 (3.35)	133.0 (5.20)	84.0 (3.31)	86.0 (3.39)	133.0 (5.20)	86.0 (3.39)	100.0 (3.94)	138.5 (5.46)
质量 (克)	11.3	17.4	6.4	6.4	7.9	6.2	7.0	7.5



100 mm – 200 mm – 300 mm系列

- 用于MP700
- 这些测针有内置破裂保护

订货号	*A-5003-1075 碳纤维	A-5003-3461 碳纤维	A-5003-7306 碳纤维	A-5003-6510 碳纤维	A-5003-6511 碳纤维	A-5003-6512 碳纤维
A 测球直径 mm (in.)	6.0 (0.24)	8.0 (0.32)	6.0 (0.24)	6.0 (0.24)	6.0 (0.24)	6.0 (0.24)
B 长度 mm (in.)	200.0 (7.88)	300.0 (11.82)	50.0 (1.97)	100.0 (3.94)	150.0 (5.91)	200.0 (7.88)
C 测杆直径 mm (in.)	4.5 (0.18)	4.5 (0.18)	4.5 (0.18)	4.5 (0.18)	4.5 (0.18)	4.5 (0.18)
D EWL* mm (in.)	186.0 (7.33)	300.0 (11.82)	36.0 (1.42)	88.0 (3.39)	138.0 (5.46)	186.0 (7.33)
质量 (克)	8.7	10.4	4.1	6.2	7.5	8.7

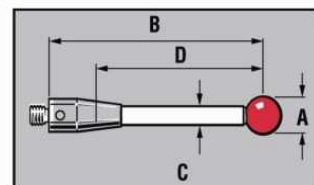

M4星形测针

订货号	A-5000-6462 陶瓷	A-5000-7098 陶瓷
测球 mm (in.)	6.0 (0.24)	6.0 (0.24)
长度 mm (in.)	100.0 (3.94)	50.0 (1.97)
测杆直径mm (in.)	4.5 (0.18)	4.5 (0.18)
EWL* mm (in.)	86.0 (3.39)	36.0 (1.42)
质量 (克)	7.5	6.0

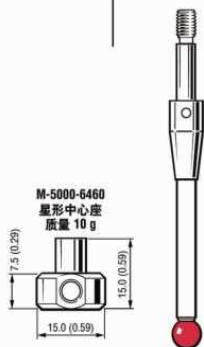

盘形测针

订货号	A-5000-7596	A-5000-7597	A-5000-7598
直径 A mm (in.)	Ø30.0 (1.19)	Ø35.0 (1.38)	Ø50.0 (1.97)
直径 B mm (in.)	Ø21.0 (0.83)	Ø21.0 (0.83)	Ø23.0 (0.91)
C mm (in.)	2.2 (0.09)	2.2 (0.09)	3.0 (0.12)
D mm (in.)	3.0 (0.12)	3.0 (0.12)	4.0 (0.16)
质量 (克)	8.01	9.57	13.55

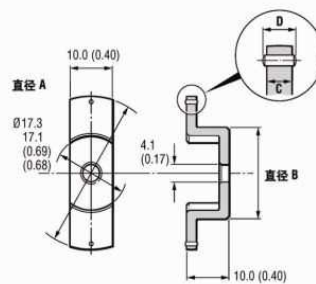

旋转接头

订货号	M-5000-7591	M-5000-7592
长度 A mm (in.)	10.0 (0.40)	13.5 (0.54)
长度 B mm (in.)	12.5 (0.50)	16.0 (0.63)
质量 (克)	2.76	3.70

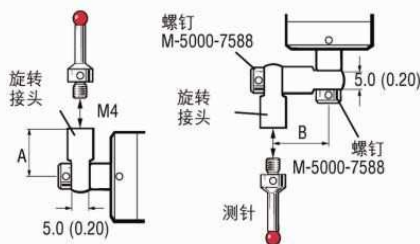

测针曲柄

订货号	M-5000-7589	M-5000-7590
长度 A mm (in.)	21.9 (0.86)	27.6 (1.09)
质量 (克)	6.07	6.94

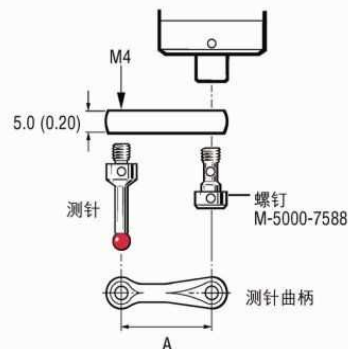

雷尼绍

M4 测针

碰撞保护装置

订货号	M-5000-7582	M-5000-7587	M-5000-7588	M-2085-0069	A-5003-5171	M-2197-0156	M-2197-0150
	不锈钢	不锈钢	不锈钢	银质钢	银质钢	银质钢	银质钢
长度 mm (in.)	8.0 (0.32)	8 (0.32)	10 (0.40)	12 (0.48)	15.2 (0.60)	9.0 (0.36)	16.0 (0.63)
质量 (克)	1.8	1.4	1.5	2.7	4.6	1.5	2.1
适用于	LP2	LP2	LP2	MP10	TS27R	HPMA	HPMA
				MP12		HPRA	HPRA
				MP700		HPPA	HPPA
				MP18			
				MP16			
				MP3			
				MP11			
使用P-TL09-0003 工具紧固							



订货号	M-2008-0333	M-2008-0604	M-2008-0605	M-2048-2093	M-2116-0127
	银质钢	银质钢	银质钢	银质钢	银质钢
长度 mm (in.)	13.3 (0.52)	22.3 (0.88)	30.3 (1.19)	13.5 (0.53)	19.0 (0.75)
质量 (克)	2.43	3.6	4.5	1.37	2.2
适用于	TS20	TS20	TS20	RP1/2	TSA



对刀用测针

订货号	A-5000-3212 不锈钢	A-5000-6701 不锈钢	A-5000-6713 铝	A-5000-6403 不锈钢
总长度 mm (in.)	53.0 (2.09)	43.0 (1.70)	96.5 (3.80)	32.5 (1.28)
测杆直径 mm (in.)	4.5 (0.18)	4.5 (0.18)	7.5 (0.30)	5.4 (0.22)
质量 (克)	4.5	4.3	21.9	11.0

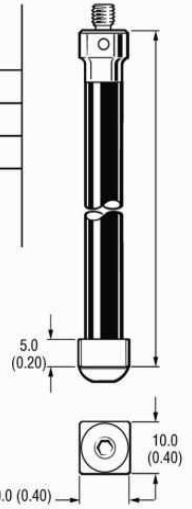

订货号	A-2197-0157 钨钢	A-2197-0158 钨钢	A-2197-0159 钨钢	A-2197-0160 钨钢	A-2197-0161 钨钢	A-2197-0162 钨钢
长度 mm (in.)	14.2 (0.56)	19.57 (0.77)	29.5 (1.16)	34.5 (1.36)	39.5 (1.55)	49.5 (1.95)
质量 (克)	14.86	16.0	18.3	19.6	20.17	20.9
适用于	HPPA HPMA HPRA	HPPA HPMA HPRA	HPPA HPMA HPRA	HPPA HPMA HPRA	HPPA HPMA HPRA	HPPA HPMA HPRA

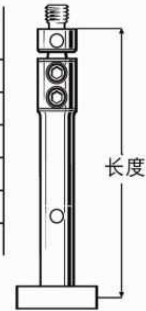

订货号	A-2008-0601 钨钢	A-2008-0602 钨钢	A-2008-0603 钨钢	A-2048-2050 钨钢	A-2048-2051 钨钢	A-2116-0140 钨钢	A-2116-0141 钨钢
长度 mm (in.)	15.4 (0.61)	24 (0.96)	32.4 (1.27)	23.2 (0.91)	32.0 (1.26)	32.0 (1.26)	42.0 (1.65)
质量 (克)	9.1	8.0	8.95	18.14	20.64	13.56	16.05
适用于	TS20	TS20	TS20	HPA (M6 MTG)	HPA (M6 MTG)	TSA	TSA

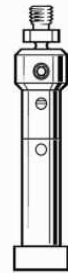

订货号	A-2116-0142
长度 mm (in.)	30.3 (0.40)
质量 (克)	1.5 (0.06)
用于	TSA

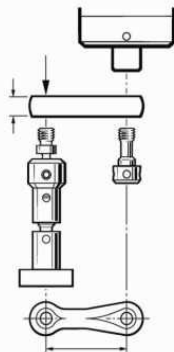

TS27R测针 — 平行安装（非M4） — 不适用于TS27测头

订货号	A-2008-0382 碳化钨	A-2008-0384 陶瓷
总长度 mm (in.)	23.0 (0.91)	22.0 (0.87)
质量 (克)	12.1	7.1

TS27R测针转换组件，可用于卧式加工中心 (A-2008-0448)

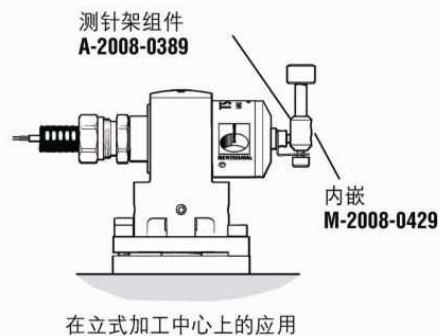

*订单还需要3 x P-SC13-0403





测针加长杆

订货号	M-5000-7583 不锈钢	M-5000-7584 不锈钢	M-5000-7585 不锈钢	M-5000-7586 不锈钢	A-5000-7754 陶瓷	A-5000-7755 陶瓷	A-5000-7727 陶瓷
长度 mm (in.)	10.0 (0.40)	15.0 (0.60)	20.0 (0.79)	30.0 (1.19)	30.0 (1.19)	50.0 (1.97)	100.0 (3.94)
加长杆直径 mm (in.)	7.0 (0.28)	7.0 (0.28)	7.0 (0.28)	7.0 (0.28)	7.4 (0.30)	7.4 (0.30)	7.4 (0.30)
质量 (克)	2.4	3.7	4.8	7.4	5.1	6.7	10.6

现有整套测针组件 - 订货号 A-5000-7676

M4数字化扫描系统用测针

半球形测针（公制）







订货号	A-5000-7718	A-5000-7719	A-5000-7720	A-5000-7721	A-5000-7722
测球直径 mm (in.)	8.0 (0.32)	10.0 (0.40)	12.0 (0.48)	16.0 (0.63)	20.0 (0.79)
长度 mm (in.)	10.5 (0.42)	10.5 (0.42)	10.5 (0.42)	11.5 (0.46)	11.5 (0.46)
质量 (克)	3.4	3.9	4.6	7.2	10.9
					

半球形测针（公制）

订货号	A-5000-7723	A-5000-7724	A-5000-7725
测球直径 mm (in.)	25.0 (0.99)	32.0 (1.26)	38.0 (1.50)
长度 mm (in.)	12.5 (0.50)	9.5 (0.38)	9.5 (0.38)
质量 (克)	18.7	19.6	28.5



阳极氧化铝半球形（英制）

订货号	A-5000-7710	A-5000-7711	A-5000-7712	A-5000-7713	A-5000-7714	A-5000-7715
测球直径 in. (mm)	5/16 (8.0)	3/8 (9.6)	1/2 (12.7)	5/8 (15.9)	3/4 (19.1)	1 (25.4)
长度 mm (in.)	10.5 (0.42)	10.5 (0.42)	10.5 (0.42)	11.5 (0.46)	11.5 (0.46)	12.5 (0.50)
质量 (克)	3.4	3.8	4.9	7.1	9.9	19.6
						

碳化钨球形测针（不锈钢测杆）

订货号	A-5000-7670	A-5000-7671	A-5000-7672	A-5000-9685	A-5000-9697
A 测球直径 mm (in.)	5.0 (0.20)	5.0 (0.20)	5.0 (0.20)	5.0 (0.20)	3.0 (0.12)
B 长度 mm (in.)	50.0 (1.97)	100.0 (3.94)	150.0 (5.91)	54.0 (2.12)	55.0 (2.17)
C 测杆直径 mm (in.)	4.4 (0.17)	4.4 (0.17)	4.4 (0.17)	3.9 (0.15)	1.9 (0.07)
D EWL* mm (in.)	32.0 (1.26)	85.0 (3.35)	120.0 (4.73)	50.0 (1.97)	25.0 (0.99)
质量 (克)	6.2	11.9	18.2	6.9	3.8

